

Intelligent SFP Bi-Directional Transceiver Module for Gigabit Ethernet and Fast Ethernet

FEATURES



- RoHS compliant
- Digital Diagnostic SFF-8472, Rev. 9.5 MSA compliant
- Support Multi-Rate for Gigabit Ethernet and Fast Ethernet
- Simplex LC connector with 1490nm Transmitter and 1310nm Receiver
- Single + 3.3V power supply and TTL logic interface
- Bellcore GR-468 compliant
- Laser class 1 product which comply with the requirements of IEC 60825-1 and IEC 60825-2

Description

The SPBD-1250xxxx series are hot pluggable 3.3V Small-Form-Factor (SFP) Bi-Directional transceiver module designed expressly for high-speed communication applications that require rates of up to 1250Mbit/sec. It is compliant with the Gigabit Ethernet and Fast Ethernet standards, as well as the SFP Multisource Agreement (MSA).

The SPBD-1250xxxx transceivers provide with the LC receptacle that is compatible with the industry standard LC connector. The transceiver is also compatible with industry standard RFT connector and cage. It also includes a LOS (Loss Of Signal) circuit that provides a TTL logic-high output when an unusable optical signal level is detected.

The module includes 1490nm un-cool DFB laser, InGaAs PIN, Preamplifier and WDM filter in a high-integrated optical assembly for high-density system application. The SFP Bi-Directional transceiver can upgrade transmission capacity very convenient without installing new fibers.

Application

- IEEE 802.3ah 1000BASE-BX
- IEEE 802.3ah 100BASE-BX
- Gigabit Ethernet/ Fast Ethernet
- FTTx WDM Broadband Access

Performance

- SPBD-1250B4Q1R data link up to 10km in 9/125um single mode fiber.

1. Absolute Maximum Ratings

Parameter	Symbol	Min.	Typ.	Max.	Unit	Note
Storage Temperature	Ts	-40		85	°C	
Storage Ambient Humidity	HA	5		95	%	
Power Supply Voltage	Vcc	0		5	V	
Signal Input Voltage		-0.3		Vcc+0.3	V	
Optical Input Power (Peak)				+3	dBm	

2. Recommended Operating Conditions

Parameter	Symbol	Min.	Typ.	Max.	Unit	Note
Operating Case Temperature	Tc	-5		75	°C	Note (1)
Ambient Humidity	HA	5		85	%	Non-condensing
Power Supply Voltage	Vcc	3.135	3.3	3.465	V	
Power Supply Current	Icc			300	mA	
Power Supply Noise Rejection				100	mVp-p	100Hz to 1MHz
Data Rate		1250 -100ppm	1250	1250 +100ppm	Mbps	
Transmission Distance				10	km	

Note (1). Measured on top side of case front center.

3. Specification of Transmitter

Parameter	Symbol	Min.	Typ.	Max.	Unit	Note
Average Launched Power	P _O	-9	-6	-3	dBm	Note (1)
Optical Extinction Ratio	ER	9			dB	
Optical Modulation Amplitude	OMA	195 -7.1			uW dBm	
Center Wavelength	λ _c	1480	1490	1500	nm	DFB Laser
Spectrum Width (-20dB)	σ			0.88	nm	
Side Mode Suppression Ratio	SMSR	30			dB	
Transmitter OFF Output Power	P _{Off}			-45	dBm	
Optical Rise/Fall Time	t _r /t _f			260	ps	Note (2)
Deterministic Jitter	DJ			80	ps	
Total Jitter	TJ			227	ps	Note (3)
Relative Intensity Noise	RIN ₁₂ OMA			-113	dB/Hz	
Optical Return Loss Tolerance	ORLT			12	dB	
Transmitter Reflectance				-12	dB	
Output Eye Mask {X1,X2,Y1,Y2,Y3}	Compliant with IEEE 802.3ah standard {0.22,0.375,0.20,0.20,0.30}					Note (4)

Note (1). Launched power (avg.) is power coupled into a single mode fiber.

Note (2). These are unfiltered 20-80% values.

Note (3). Measure at 2⁷-1 NRZ PRBS pattern.

Note (4). Eye Mask definition

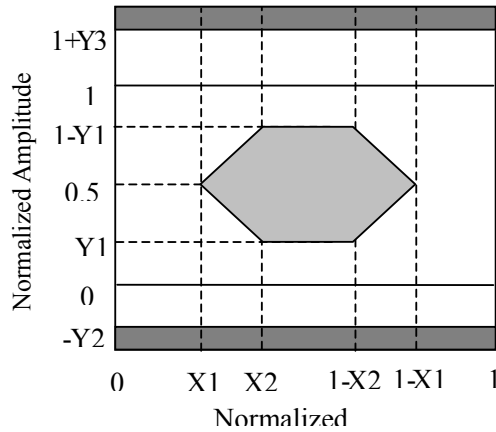

4. Specification of Receiver

Parameter	Symbol	Min.	Typ.	Max.	Unit	Note
Input Optical Wavelength	λ_{IN}	1260		1360	nm	PIN-PD
Receiver Sensitivity	P_{IN}			-23	dBm	Note (1)
Input Saturation Power (Overload)	P_{SAT}	-3			dBm	
Receive Sensitivity OMA	OMA	5.0 -21.1			uW dBm	Note (2)
LOS-Deassert Power	P_A	-		-24	dBm	
LOS-Assert Power	P_D	-44			dBm	Note (3)
LOS Hysteresis	P_A-P_D	0.5	2	6	dB	
Receiver Reflectance				-12	dB	Note (4)
Stressed Receive sensitivity		-15.4			dBm	
Stressed Receive sensitivity OMA		44.8 -13.5			uW dBm	
Vertical Eye-closure Penalty	V ECP	2.6			dB	
Deterministic Jitter	DJ			170	ps	
Total Jitter	TJ			266	ps	
Output Data Rise/Fall time	t_r/t_f			260	ps	Note (5)
Receiver 3dB upper cutoff frequency				1500	MHz	

Note (1). Measured with 1310nm, ER=9dB; BER =10^{-12}@PRBS=2⁷-1 NRZ

Note (2). Specified with minimum optical extinction ration of 9dB.

Note (3). When LOS asserted, the data output is Low-level (fixed)

Note (4). When the terminal is viewed from the optical path, the reflection toward the optical path of the optical signal with a central wavelength of 1260nm to 1360nm transmitted to terminal.

Note (5). These are 20%~80% values

5. Electrical Interface Characteristics

Parameter	Symbol	Min.	Typ.	Max.	Unit	Note
Transmitter						
Total Supply Current	I_{CC}			A	mA	Note (1)
Differential Data Input Swing	VDT	500		2400	mV _{p-p}	
Differential line input Impedance	R_{IN}	80	100	120	Ohm	
Transmitter Disable Input-High	V_{DISH}	2		V_{CC}	V	Note (2)
Transmitter Disable Input-Low	V_{DISL}	0		0.8	V	
Transmitter Fault Output-High	V_{TXFH}	2		$V_{CC}+0.3$	V	
Transmitter Fault Output-Low	V_{TXFL}	0		0.8	V	
Transmitter Fault Pull up Resistor	R_{TX_FAULT}	4.7		10	k Ω	Note (3)
Receiver						
Total Supply Current	I_{CC}			B	mA	Note (1)
Differential Data Output Swing	VDR	400		900	mV _{p-p}	Note (4)
LOS Output Voltage-High	V_{LOSH}	2		$V_{CC}+0.3$	V	
LOS Output Voltage-Low	V_{LOSL}	0		0.8	V	
Receiver LOS Load	R_{RXLOS}	4.7		10	k Ω	Note (3)

Note (1). A (TX)+ B (RX) = 300mA

(A: Not include termination circuit; B: using a resistor of 150 Ω between Data-output and ground)

Note (2). There is an internal 4.7 to 10k Ω pull-up resistor to VccT.

Note (3). Pull up to V_{CC} on host Board.

Note (4). Internally AC coupled with CML output, but requires a 100Ohm differential termination at or internal to Serializer/ Deserializer.

6. Enhanced Digital Diagnostic Interface

The memory map in the following describes an extension to the memory map defined in SFP MSA. The enhanced interface uses the two wire serial bus address 1010001X(A2h) to provide diagnostic information about the module's present operating conditions.

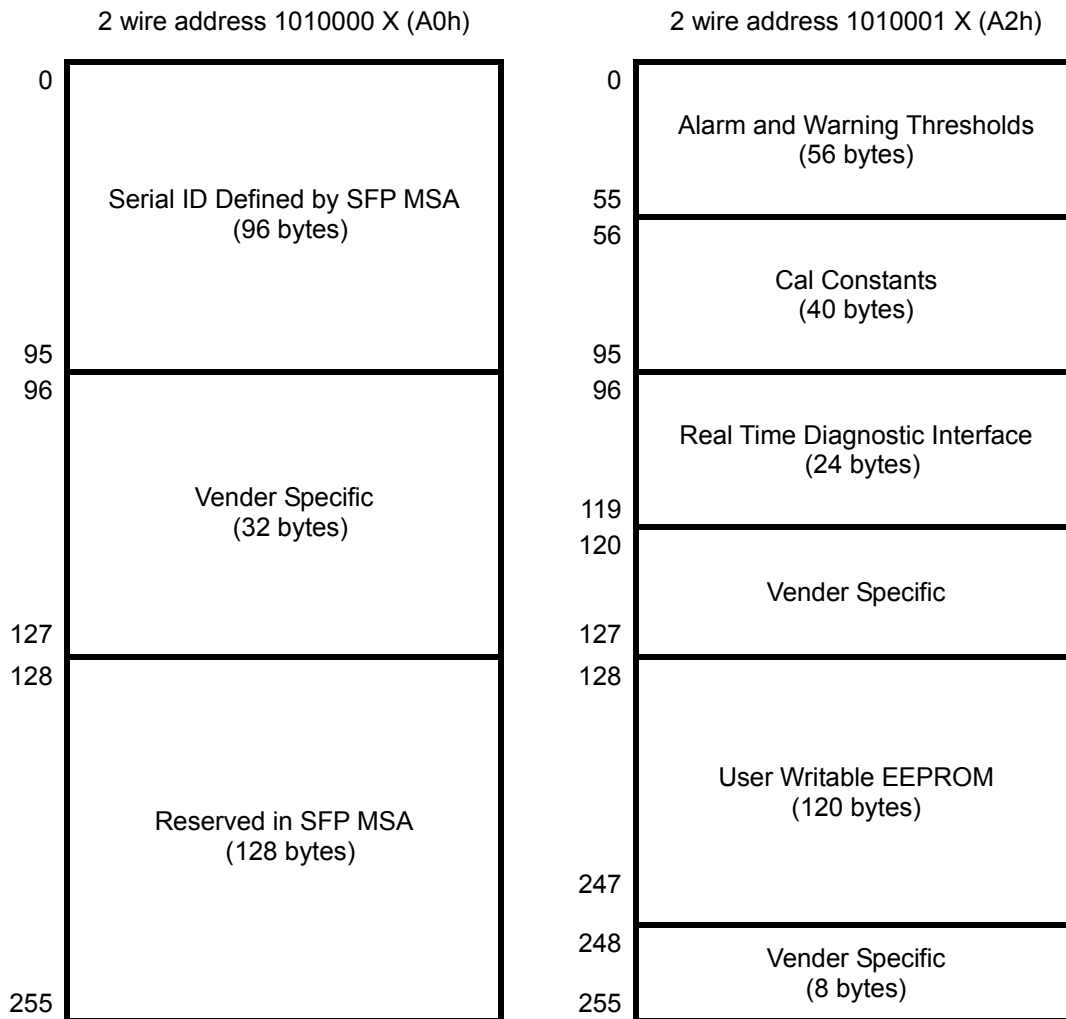

7. Digital Diagnostic Monitor Accuracy

Parameter	Accuracy	Unit	Calibration	Note
Transceiver Internal Temperature	± 3°C	°C	Internal	TC=-5~+75°C
Power Supply Internal Voltage	± 3%	V	Internal	VCC=3.3V±5%
TX Bias Current	± 10%	mA	Internal	Specified by nominal bias value
TX Optical Power	± 3dB	dBm	Internal	-9 to -3dBm
RX Optical Power	± 3dB	dBm	Internal	-23 to -3dBm

Note. Temperature and Voltage is measured internal to the transceiver.

8. Pin Description

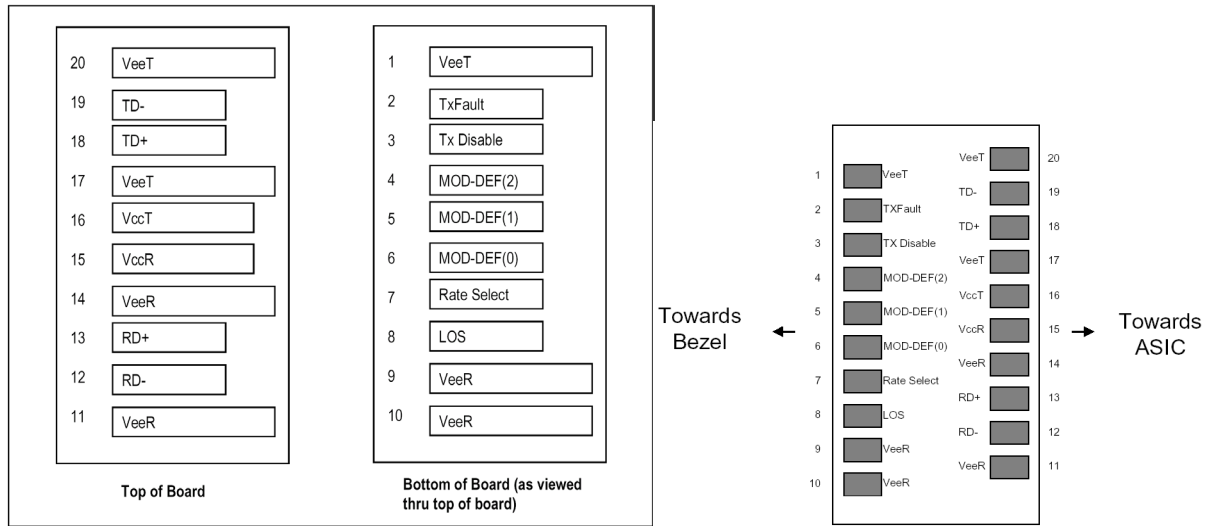

SFP Transceiver Electrical Pad Layout

Host Board Connector Pad Layout

Pin Function Definitions

Pin Num.	Name	Function	Plug Seq.	Notes
1	VeeT	Transmitter Ground	1	Note (1)
2	TX Fault	Transmitter Fault Indication	3	Note (2)
3	TX Disable	Transmitter Disable	3	Note (3)
4	MOD-DEF2	Module Definition 2	3	Note (4), 2 wire serial ID interface
5	MOD-DEF1	Module Definition 1	3	Note (4), 2 wire serial ID interface
6	MOD-DEF0	Module Definition 0	3	Note (4), Grounded in Module
7	Rate Select	Not Connect	3	Function not available
8	LOS	Loss of Signal	3	Note (5)
9	VeeR	Receiver Ground	1	
10	VeeR	Receiver Ground	1	
11	VeeR	Receiver Ground	1	
12	RD-	Inv. Received Data Out	3	Note (6)
13	RD+	Received Data Out	3	Note (6)
14	VeeR	Receiver Ground	1	
15	VccR	Receiver Power	2	Note (7)
16	VccT	Transmitter Power	2	Note (7)
17	VeeT	Transmitter Ground	1	
18	TD+	Transmit Data In	3	Note (8)
19	TD-	Inv. Transmit Data In	3	Note (8)
20	VeeT	Transmitter Ground	1	

Plug Seq.: Pin engagement sequence during hot plugging.

Notes:

- 1) Circuit ground is internally isolated from frame (chassis) ground. Tx GND and Rx GND may be internally isolated within the TRx module.
- 2) TX Fault is an open collector/drain output, which should be pulled up with a 4.7K~10K Ω resistor on the host board. Pull up voltage between 2.0V and VccT+0.3V. The output indicates Low when the transmitter is operating normally, and High with a laser fault including laser end-of-life. In the low state, the output will be pulled to less than 0.8V.
- 3) TX disable is an input that is used to shut down the transmitter optical output. It is pulled up within the module with a 4.7 – 10 K Ω resistor. Its states are:

Low (0 – 0.8V):	Transmitter on
(>0.8, < 2.0V):	Undefined
High (2.0 – 3.465V):	Transmitter Disabled
Open:	Transmitter Disabled
- 4) Mod-Def 0,1,2. These are the module definition pins. They should be pulled up with a 4.7K – 10K Ω resistor on the host board. The pull-up voltage shall be VccT or VccR.
Mod-Def 0 is grounded by the module to indicate that the module is present
Mod-Def 1 is the clock line of two-wire serial interface for serial ID
Mod-Def 2 is the data line of two-wire serial interface for serial ID
- 5) LOS (Loss of Signal) is an open collector/drain output, which should be pulled up with a 4.7K – 10K Ω resistor. Pull up voltage between 2.0V and VccR+0.3V. When high, this output indicates the received optical power is below the worst-case receiver sensitivity. Low indicates normal operation. In the low state, the output will be pulled to less than 0.8V.
- 6) RD-/+ : These are the differential receiver outputs. They are AC coupled 100 Ω differential lines which should be terminated with 100 Ω (differential) at the user SERDES. The AC coupling is done inside the module and is thus not required on the host board.
- 7) VccR and VccT are the receiver and transmitter power supplies. They are defined as 3.3V \pm 5% at the SFP connector pin. Recommended host board power supply filtering is shown below page. Inductors with DC resistance of less than 1 Ohm should be used in order to maintain the required voltage at the SFP input pin with 3.3V supply voltage. When the recommended supply-filtering network is used, hot plugging of the SFP transceiver module will result in an inrush current of no more than 30 mA greater than the steady state value.
- 8) TD-/+ : These are the differential transmitter inputs. They are AC-coupled, differential lines with 100 Ω differential termination inside the module. The AC coupling is done inside the module and is thus not required on the host board. The inputs will accept differential swings of 500 – 2400 mV (250 – 1200 mV single-ended), though it is recommended that values between 500 and 1200 mV differential (250 – 600 mV single-ended) be used for best EMI performance.

9. Recommend Interface Circuit

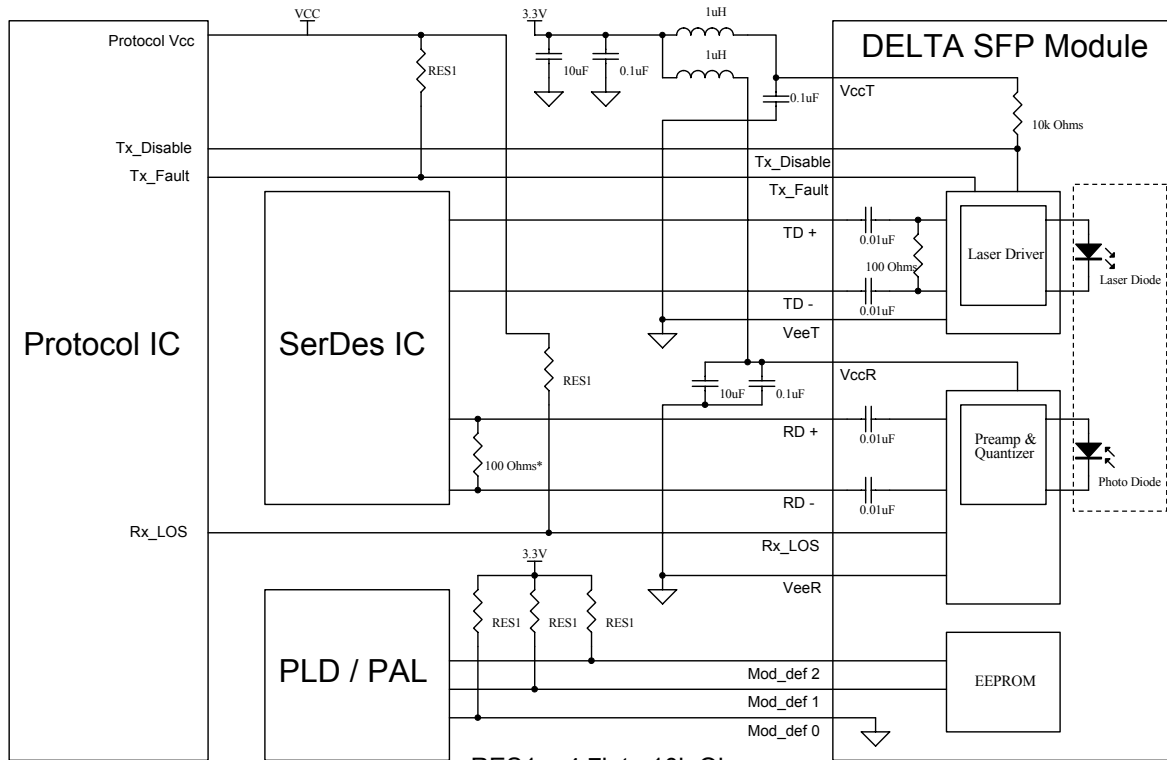

RES1 = 4.7k to 10k Ohms

* Depends on SerDes IC used

SFP Host Board Schematic

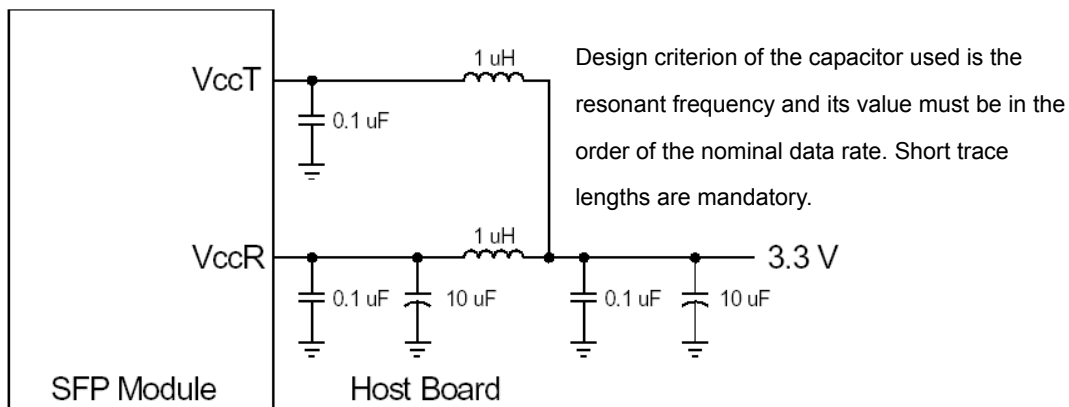

Design criterion of the capacitor used is the resonant frequency and its value must be in the order of the nominal data rate. Short trace lengths are mandatory.

Recommended Host Board Supply Filtering Network

10. Outline Dimensions

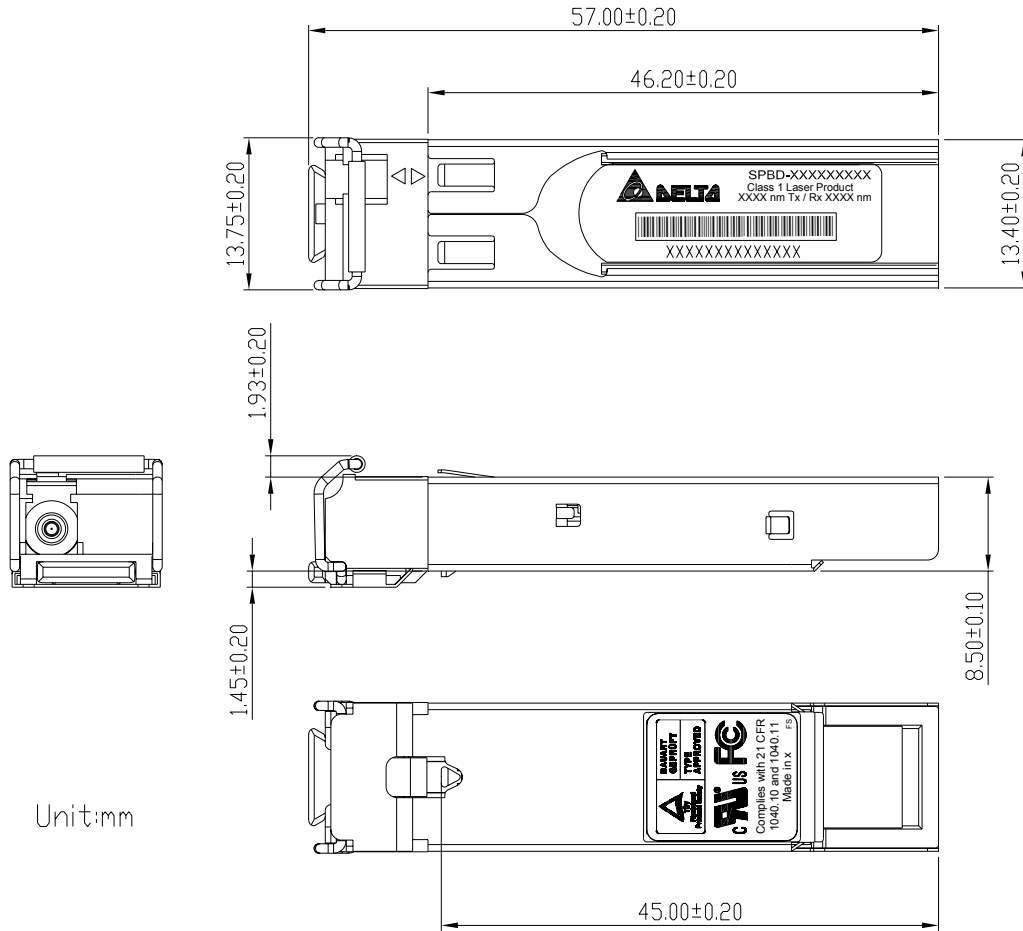

Unit:mm

S/N

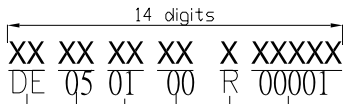

- S/N : (00001~99999)
- Rework : Rework=R or No-rework=0
- Vender NOTE : Free or 00
- Week (52Weeks/Year) : 1月2日=01
- Year : 2005=05
- Vender CODE : DELTA=DE

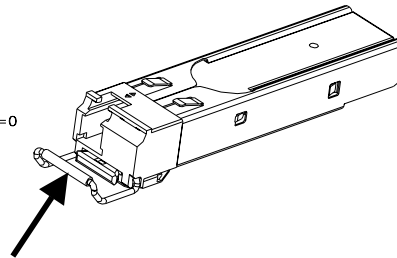

Transmitter Wavelength	Latch Color Identifier
1310nm	Black
1490nm	Violet

11. Regulatory Compliance

Feature	Test Method	Reference	Performance
Electrostatic Discharge (ESD) to the Electrical Pins	Human Body Model (HBM)	MIL-STD-883E Method 3015.7 EIA-JESD22-A114	(1) Satisfied with electrical characteristics of product spec. (2) No physical damage
	Machine Model (MM)	EIA-JESD22-A115	
Electrostatic Discharge (ESD) to the Simplex Receptacle	Contact Discharge	IEC/EN 61000-4-2	
	Air Discharge	IEC/EN 61000-4-2	
Radio Frequency Electromagnetic Field Immunity		IEC/EN 61000-4-3	
Electromagnetic Interference (EMI)		FCC Part 15 Class B EN 55022 Class B (CISPR 22A)	
Laser Eye Safety	FDA/CDRH	FDA 21CFR 1040.10, 1040.11	CDRH File # 0420993
	TUV	IEC/EN 60825-1 IEC/EN 60825-2	TUV Certificate # R50032471
Component Recognition	TUV	IEC/EN 60950	
	UL/CSA	UL 60950	UL File # E239394

Appendix A. Document Revision

Version No.	Date	Description
S0	2006-08-15	Preliminary datasheet
S1	2007-03-12	Change the specification of Optical Rise/Fall Time from 200ps to 260ps.